

BẢNG KÊ NGUYÊN VẬT LIỆU

Số TT	Tên phụ kiện	Tải trọng phá hoại	Số lượng	Vật liệu chế tạo
1	Ma ní	640	01	Hiện hữu
2	Mắt nối chuyển hướng	420	01	Hiện hữu
3	Mắt nối điều chỉnh	420	01	Hiện hữu
4	Mắt nối	420	01	Hiện hữu
5	Khánh	420	01	Hiện hữu
6	Vòng treo đầu tròn	210	02	Hiện hữu
7	Mỏ phóng		02	Thép mạ kẽm - Thay mới
8	Cách điện U210BP	210	2x13	Gôm/thủy tinh - Thay mới
9	Vòng đẳng thế		02	Thép mạ kẽm - Thay mới
10	Mắt nối	210	01	Hiện hữu
11	Khánh	420	02	Hiện hữu
12	Mắt nối đơn	210	02	Hiện hữu
13	Mắt nối điều chỉnh	210	02	Hiện hữu
14	Khóa néo		02	Hiện hữu

Ghi chú:

- Tất cả các kích thước tính bằng đơn vị mm
- Tải trọng chuỗi cách điện là 2x160kN
- Số lượng bát: 2x13 bát loại U210BP đang tính toán với dòng dò bát là 525mm/kV
- Chuỗi cách điện sử dụng cho dây dẫn 2xACSR 400/93

Dòng dò quy định (mm/kV)	Ký hiệu cách điện	Tổng chiều dài đường dò (mm)
25	NDD.2.210(A)	6825

CÔNG TY TRUYỀN TẢI ĐIỆN TẠI ĐIỆN 1
TRUYỀN TẢI ĐIỆN NINH BÌNH

ĐƯỜNG DÂY 220KV
THÁI BÌNH - TIỀN HẢI - TRỰC NINH

P.Giám đốc	Đỗ Đình Dũng		CHUỖI NÉO KÉP DÂY DẪN: NDD.2.210(A)	
Kiểm tra	Lê Xuân Tiến		BVTC	2024
Người vẽ	Đỗ Xuân Điện			

THIS DRAWING IS THE PROPERTY OF "TAG CORPORATION" AND SHOULD NOT BE COPIED OR REPRODUCED WITHOUT PROPER AUTHORIZATION.

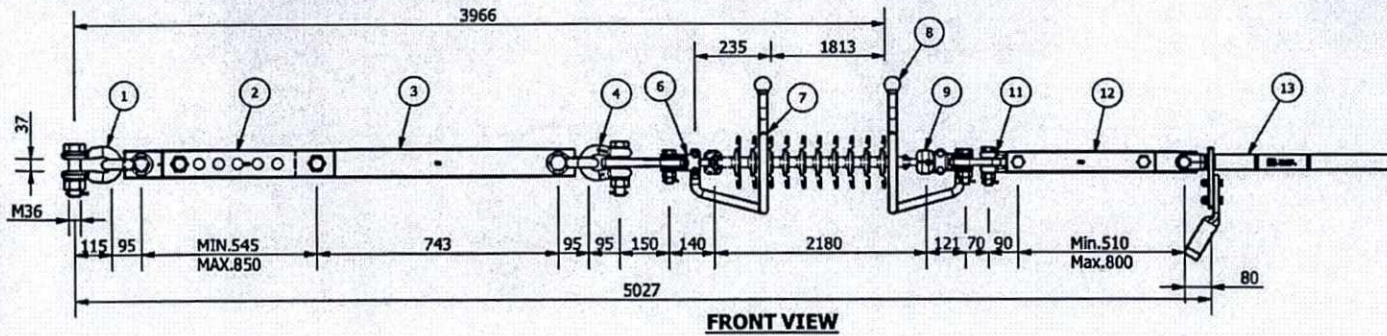

FRONT VIEW

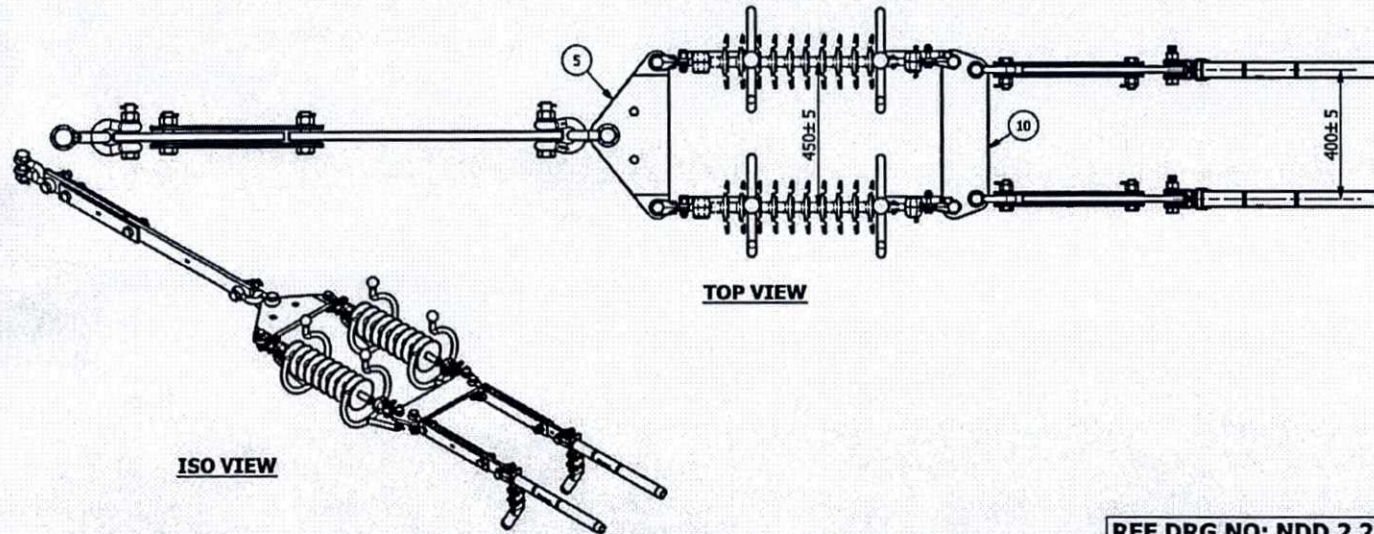

TOP VIEW

ISO VIEW

ITEM CODE F 0 0 2 3 9 0 0 2

TECHNICAL DATA

1. ASSEMBLY MINIMUM ULTIMATE TENSILE STRENGTH - 420 kN.
2. BALL & SOCKET DESIGNATION - 20MM AS PER IEC - 120.
3. BALL & SOCKET LOCKING BY R-CLIP AS PER IEC-372, MADE OF S.S.
4. FERROUS PARTS-HOT DIP GALVANIZED AS PER ISO 1461.
5. GENERAL TOLERANCE UNLESS OTHERWISE SPECIFIED IS ±3%.
6. TOLERANCE ON LENGTH OF HARDWARE IS ±2%.
7. COMPOSITE INSULATOR NOT IN TAG'S SCOPE OF SUPPLY.
8. HARDWARE SUITABLE FOR ACSR/Mz 400/93 (ø29.1) CONDUCTOR.
9. WEIGHT OF THE STRING - 138.57 kg (APPROX)
10. ALL DIMENSIONS ARE IN mm.
11. WEIGHT IS INDICATIVE ONLY.
12. SHORT CIRCUIT CURRENT CAPACITY - 41.1kA / 1 Sec (Maximum).

PRODUCT CODE: DT/T2/LJ/C

Project Name: Package 03: Supply and transport of insulators and fittings, OPGW cable and accessories for 220kV Thai Binh - Tien Hai - Truc Ninh double circuit transmission line

P.O.Ref.No. -

Purchaser: M/s. NPMB

Contractor: M/s.

Manufacturer: TAG CORPORATION, CHENNAI.

REV	DATE	DESCRIPTION	APP. BY
3	24.01.2017	ITEM NO. 7 & 8 (RTAH) CHANGED	
2	14.12.2016	ITEM CODE, PRODUCT CODE, COMP.CODE, ADDED	
1	18.10.2016	(ITEM NO:7,8) NEW ARCING HORNS ADDED	

REVISION HISTORY

ITEM NAME: 220KV DOUBLE TENSION STRING FOR TWIN ACSR/Mz ø29.1 CONDUCTOR

DRG.NO: TAG/E/DT/T2/LJ/C

<p>TAG CORPORATION CHROMEPET, CHENNAI - 600 044 EXPORT - TAMILNADU, INDIA.</p>	DATE	08.08.2016
	DRAWN BY	B.A
	CKD. BY	R.M
	APP. BY	V.T.C
	SCALE: 1:15	

SL.NO	DESCRIPTION	MATERIAL	DRG. NO	COMP.CODE	ITEM CODE	UTS (KN)	QTY (NOS.)
13	DEAD END ASSEMBLY	GALVANIZED STEEL	DEA3011	DEA3011	G00212094	-	2
12	ADJUSTABLE EXTENSION PLATE	GALVANIZED STEEL	AEP4202	AEP4202	G00202037	210	2
11	CLEVIS EYE	GALVANIZED STEEL	CE4003	CE4003	G00209027	210	2
10	TRAPEZOIDAL YOKE PLATE	GALVANIZED STEEL	TZYP5026	TZYP5026	M00608235	420	1
9	H.H. SOCKET CLEVIS	GALVANIZED STEEL	HSC4300.1	HSC4300.1	G00223030	210	3
8	RING TYPE ARCING HORN	GALVANIZED STEEL	RTAH4207	RTAH4207	M00609127	-	2
7	RING TYPE ARCING HORN	GALVANIZED STEEL	RTAH4206	RTAH4206	M00609126	-	2
6	H.H BALL CLEVIS	GALVANIZED STEEL	HBC4300.1	HBC4300.1	G00260006	210	2
5	TRIANGULAR YOKE PLATE	GALVANIZED STEEL	TYP4215	TYP4215	M00608233	420	1
4	D-SHACKLE	GALVANIZED STEEL	DS4402	DS4402	G00211004	420	3
3	EXTENSION PLATE	GALVANIZED STEEL	EP4213	EP4213	M00601073	420	1
2	ADJUSTABLE EXTENSION PLATE	GALVANIZED STEEL	AEP4007	AEP4007	G00202039	420	1
1	D-SHACKLE	GALVANIZED STEEL	DS4305	DS4305	G00211048	640	1

BILL OF MATERIAL

THIS DRAWING IS THE PROPERTY OF "TAG CORPORATION" AND SHOULD NOT BE COPIED OR REPRODUCED WITHOUT PROPER AUTHORIZATION.

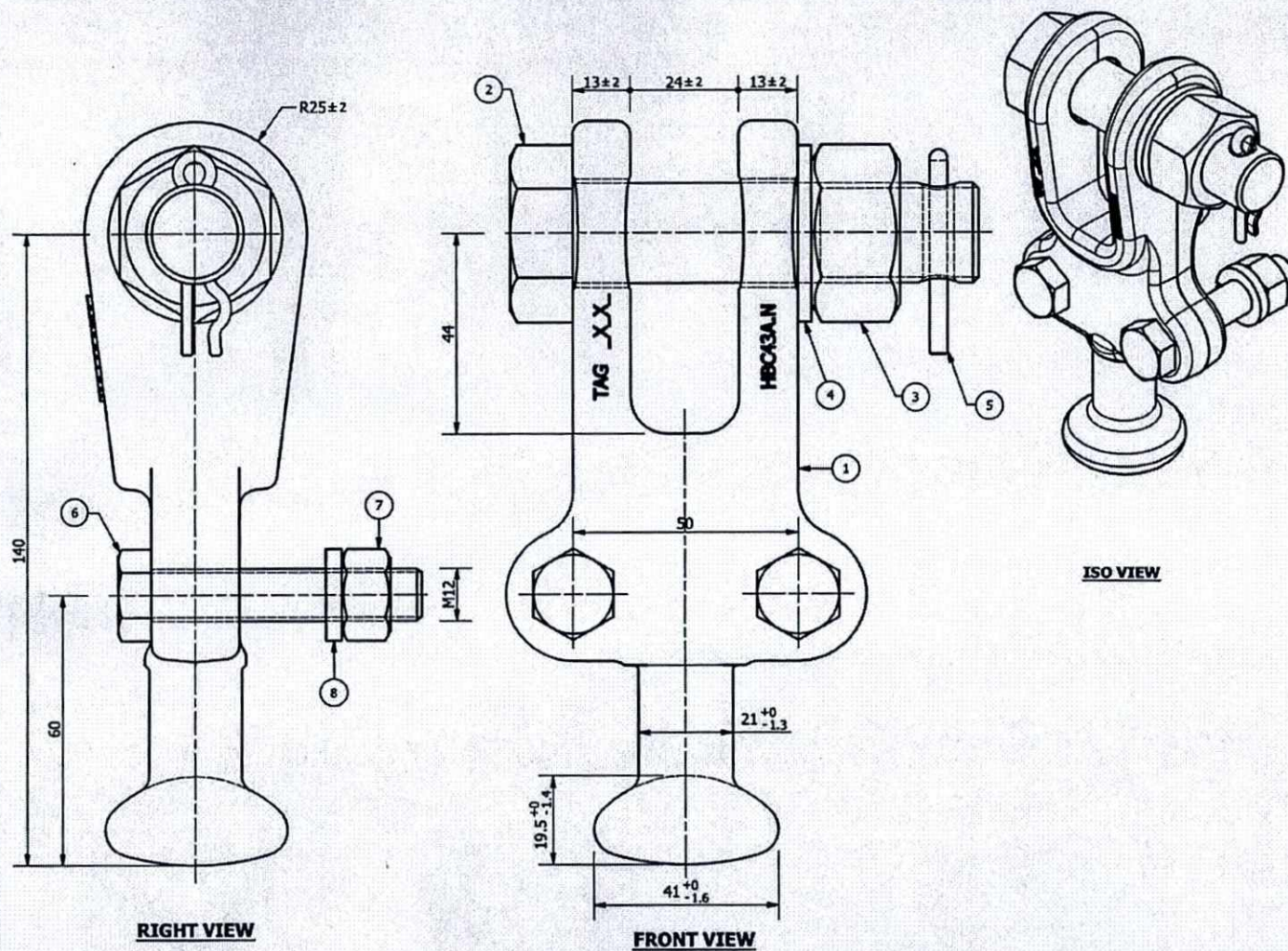

ITEM CODE G 0 0 2 6 0 0 0 6

TECHNICAL DATA

1. HOT DIP GALVANIZED AS PER ISO : 1461.
2. BREAKING STRENGTH - 210 KN
3. BALL DESIGNATION 20 mm AS PER IEC-120.
4. GENERAL TOLERANCE UNLESS OTHERWISE SPECIFIED IS ±3%.
5. TOTAL WEIGHT - 1.82 kg.
6. WEIGHT IS INDICATIVE ONLY.
7. ALL DIMENSIONS ARE IN MM.

Project Name Package 03: Supply and transport of insulators and fittings, OPGW cable and accessories for 220kV Thai Binh - Tien Hai - Truc Ninh double circuit transmission line

P.O.Ref.No. -

Purchaser M/s. NPMB

Contractor M/s.

Manufacturer TAG CORPORATION, CHENNAI.

REV	DATE	DESCRIPTION	APP. BY
-----	------	-------------	---------

REVISION HISTORY

ITEM NAME: H.H BALL CLEVIS

DRG.NO: HBC4300.1 DATE 14.12.2016

TAG CORPORATION
 CHROMEPET, CHENNAI - 600 044
 EXPORT TAMILNADU, INDIA.

DRAWN BY P.R.B
 CKD. BY R.M
 APP. BY V.T.C
 SCALE: 1:1

ITEM	DESCRIPTION	MATERIAL	ITEM CODE	UTS	QTY (NOS.)
8	SPRING WASHER (M12)	SPRING STEEL	B00211002	-	2
7	NUT (M12)	GALVANIZED STEEL (P.C.5.0)	-	-	2
6	BOLT (M12X60)-FT	GALVANIZED STEEL (P.C.5.6)	B00202013	-	2
5	SPLIT PIN(SP/001)	S.S (AISI - 304)	B00210001	-	1
4	FLAT WASHER (M22)	GALVANIZED STEEL	B00205006	-	1
3	NUT (M22)	GALVANIZED STEEL (P.C.8.0)	-	-	1
2	BOLT (M22X90)	GALVANIZED STEEL (P.C.8.8)	B00203040	-	1
1	H.H.BALL CLEVIS	GALVANIZED STEEL	M00514002	210	1

BILL OF MATERIAL

THIS DRAWING IS THE PROPERTY OF "TAG CORPORATION" AND SHOULD NOT BE COPIED OR REPRODUCED WITHOUT PROPER AUTHORIZATION.

ITEM CODE G 0 0 2 2 3 0 3 0

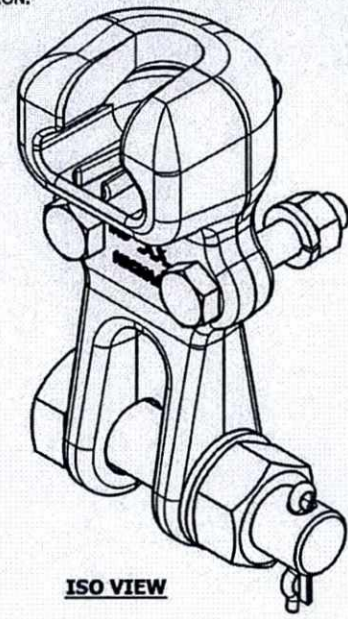
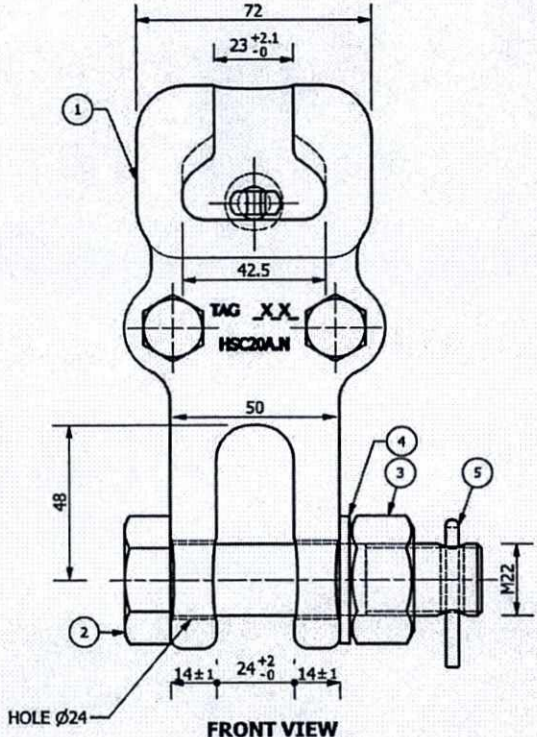
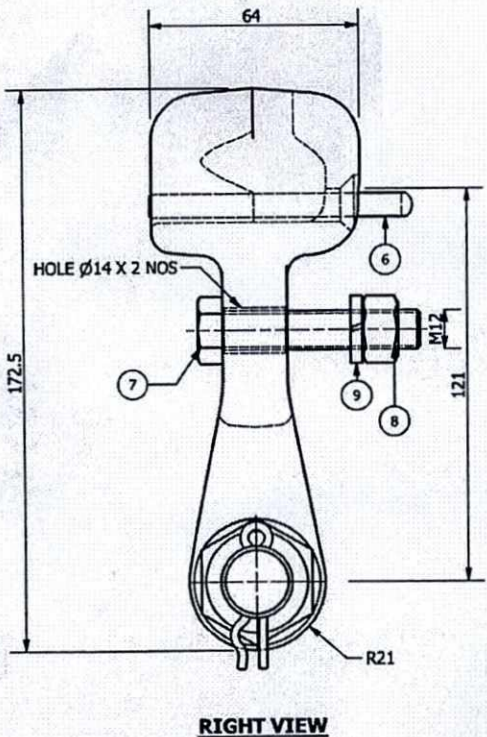

- TECHNICAL DATA**
1. HOT DIP GALVANIZED AS PER ISO : 1461.
 2. BREAKING STRENGTH - 210 KN
 3. SOCKET DESIGNATION 20 mm AS PER IEC-120.
 4. GENERAL TOLERANCE UNLESS OTHERWISE SPECIFIED IS ±3%.
 5. WEIGHT IS INDICATIVE ONLY.
 6. ALL DIMENSIONS ARE IN MM.

Project Name	Package 03: Supply and transport of insulators and fittings, OPGW cable and accessories for 220kV Thai Binh - Tien Hai - Truc Ninh double circuit transmission line
P.O.Ref.No.	-
Purchaser	M/s. NPMB
Contractor	M/s.
Manufacturer	TAG CORPORATION, CHENNAI.

ITEM	DESCRIPTION	MATERIAL 2	ITEM CODE	UTS	QTY (NOS.)
9	SPRING WASHER (M12)	SPRING STEEL	B00211002	-	2
8	NUT (M12)	GALVANIZED STEEL (P.C.5.0)	-	-	2
7	BOLT (M12X60)-FT	GALVANIZED STEEL (P.C.5.6)	B00202013	-	2
6	R-CLIP (R/C002)	S.S (AISI - 304)	B00208002	-	1
5	SPLIT PIN(SP/001)	S.S (AISI - 304)	B00210001	-	1
4	FLAT WASHER (M22)	GALVANIZED STEEL	B00205006	-	1
3	NUT (M22)	GALVANIZED STEEL (P.C.8.0)	-	-	1
2	BOLT (M22X95)	GALVANIZED STEEL (P.C.8.8)	B00203038	-	1
1	H.H. SOCKET CLEVIS	GALVANIZED STEEL	M00507021	210	1

BILL OF MATERIAL

REV	DATE	DESCRIPTION	APP. BY
REVISION HISTORY			

ITEM NAME: **H.H. SOCKET CLEVIS**

DRG.NO: HSC4300.1	DATE: 14.12.2016
DRAWN BY: P.R.B	CKD. BY: R.M
APP. BY: V.T.C	SCALE: 1:1.5

TAG CORPORATION
CHROME PET, CHENNAI - 600 044
EXPORT TAMILNADU, INDIA.